

Linear Servomotors

SGLC

(Cylinder Type)



Model Designations

● Combination of Moving Coil and Magnetic Way

S G L C - D16 A 085 A P - 750 A

Linear Σ Series Linear Servomotor (1st digit) 2nd+3rd+4th digits (2nd+3rd+4th digits) 5th digit (5th digit) 6th+7th+8th digits (6th+7th+8th digits) 9th digit (9th digit) 10th digit (10th digit) 11th+12th+13th digits (11th+12th+13th digits) 14th digit (14th digit)

1st digit Servomotor Model

Code	Specifications
C	Cylinder type

2nd+3rd+4th digits Outer Diameter of Magnetic Way

Code	Specifications
D16	16 mm
D20	20 mm
D25	25 mm
D32	32 mm

5th digit Voltage

Code	Specifications
A	200 VAC

6th+7th+8th digits Length of Moving Coil

Code	Specifications	Outer Diameter Code of Magnetic Way
085	85 mm	D16
100	100 mm	D20
115	115 mm	D16
125	125 mm	D25
135	135 mm	D20
145	145 mm	D16
165	165 mm	D32
170	170 mm	D20, D25
215	215 mm	D25
225	225 mm	D32
285	285 mm	D32

9th digit Design Revision Order of Moving Coil
A, B...

10th digit Hall Sensor

Code	Specifications
P	With hall sensor (all models)

11th+12th+13th digits Length of Magnetic Way
(See the next page)

14th digit Design Revision Order of Magnetic Way
A, B...

● Moving Coil

SGL C W - D16 A 085 A P

Linear Σ Series Linear Servomotor (1st digit) (2nd digit) (3rd+4th+5th digits) (6th digit) (7th+8th+9th digits) (10th digit) (11th digit)

1st digit Servomotor Model (Same as above combination.) 3rd+4th+5th digits Outer Diameter of Magnetic Way (Same as above combination.) 10th digit Design Revision Order A, B...

2nd digit Moving Coil/Magnetic Way 6th digit Voltage (Same as above combination.) 11th digit Hall Sensor

Code	Specifications
W	Moving Coil

7th+8th+9th digits Length of Moving Coil (Same as above combination.)

Code	Specifications
P	With hall sensor (all models)

● Magnetic Way

SGL C M - D16 750 A

Linear Σ Series Linear Servomotor (1st digit) (2nd digit) (3rd+4th+5th digits) (6th+7th+8th digits) (9th digit)

1st digit Servomotor Model (Same as above combination.) 3rd+4th+5th digits Outer Diameter of Magnetic Way (Same as above combination.) 9th digit Design Revision Order A, B...

2nd digit Moving Coil/Magnetic Way 6th+7th+8th digits Length of Magnetic Way (See the next page)

Code	Specifications
M	Magnetic Way

Note: Order the moving coil and magnetic way as a set. Contact your Yaskawa representative before purchasing them separately.

Features

- Both coil assemblies supported, easy switching from ball screws.
- Compared to ball screw systems, high-speed and high-precision positioning greatly reduces tact time.
- Unlike ball screws, no contact with machines, no lubrication oil, easy maintenance.

Application Examples

- Semiconductor equipment
- Electronic parts assembly
- Food packaging machines
- Metal processing machines
- General handling machines

◆ Magnetic Way Lengths

Moving Coil Model SGLCW-		Magnetic Way Dimensions mm						
		Standard Specifications				Special Orders		
		Code = ① mm				Length of Magnetic Way mm		
		②	③	④	⑤	Min. to Max.		
D16A	085AP 115AP 145AP	300	85	30	37.5	140	240 to 420 (30 mm increments)	
			115			110		
			145			80		
	510	45	52.5	85	45	52.5	320	480 to 750 (30 mm increments)
				115			290	
				145			260	
		750	85	560				
			115	530				
			145	500				
D20A	100AP 135AP 170AP	350	100	35	45	160	280 to 490 (35 mm increments)	
			135			125		
			170			90		
	590	50	60	100	50	60	370	555 to 870 (35 mm increments)
				135			335	
				170			300	
		870	100	650				
			135	615				
			170	580				
D25A	125AP 170AP 215AP	450	125	45	57.5	210	360 to 630 (45 mm increments)	
			170			165		
			215			120		
	750	60	72.5	125	60	72.5	480	705 to 1110 (45 mm increments)
				170			435	
				215			390	
		1110	125	840				
			170	795				
			215	750				
D32A	165AP 225AP 285AP	600	165	60	75	285	480 to 840 (60 mm increments)	
			225			225		
			285			165		
	1020	90	105	165	90	105	645	960 to 1500 (60 mm increments)
				225			585	
				285			525	
		1500	165	1125				
			225	1065				
			285	1005				

- ① Length of Magnetic Way
- ② Length of Moving Coil
- ③ Position of Support Section
- ④ Range Outside the Guaranteed Force
- ⑤ Effective Strokes

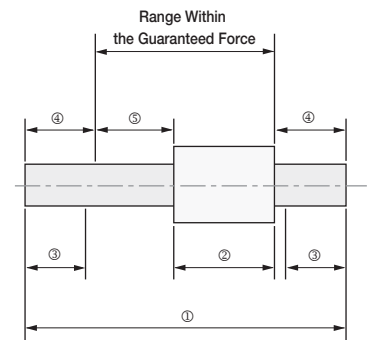

Note: ③ Range outside the guaranteed force: If any part of the moving coil is located within this range, characteristics indicated in *Force and Speed Characteristics* on page 184 cannot be satisfied.

< Calculating Length of Magnetic Way >

- ② Length of Moving Coil (mm)
- ④ Range Outside the Guaranteed Force (mm)
- ⑤ Effective Strokes (mm)



◆ Length of Magnetic Way
 $[② + ④ \times 2 + ⑤]$ (mm)

Ratings and Specifications

Time Rating: Continuous

Insulation Resistance: 500 VDC, 10 MΩ min.

Ambient Temperature: 0 to 40°C

Excitation: Permanent magnet

Withstand Voltage: 1500 VAC for one minute

Enclosure: Self-cooled

Ambient Humidity: 20% to 80% (no condensation)

Allowable Winding Temperature: 130°C (Thermal class B)

Linear Servomotor Model SGLC-		D16A			D20A			D25A			D32A		
		085A	115A	145A	100A	135A	170A	125A	170A	215A	165A	225A	285A
Peak Speed ³	m / s	4.0	4.0	4.0	4.0	4.0	4.0	4.0	4.0	4.0	4.0	4.0	4.0
Rated Force ¹	N	17	25	34	30	45	60	70	105	140	90	135	180
Rated Current ¹	Arms	0.59	0.53	0.66	0.98	0.98	1.19	1.42	1.75	3.49	1.57	2.79	2.79
Instantaneous Peak Force ¹	N	60	90	120	150	225	300	280	420	560	420	630	840
Instantaneous Peak Current ¹	Arms	2.07	2.07	2.52	4.90	4.90	5.95	5.68	6.98	12.96	7.32	13.01	13.01
Moving Coil Mass	kg	0.3	0.4	0.5	0.6	0.8	1.0	1.0	1.4	1.8	1.8	2.5	3.2
Force Constant	N / Arms	31.2	46.8	51.3	33.0	49.5	54.3	53.1	64.8	43.2	61.8	52.2	69.6
BEMF Constant	V / (m/s)	10.4	15.6	17.1	11.0	16.5	18.1	17.7	21.6	14.4	20.6	17.4	23.2
Motor Constant	N / √w	4.8	5.9	6.7	7.5	9.2	10.4	10.0	12.4	15.4	16.2	20.0	23.0
Electrical Time Constant	ms	0.18	0.18	0.17	0.38	0.32	0.41	0.18	0.59	0.65	0.76	1.18	1.58
Mechanical Time Constant	ms	13.1	11.7	11.3	10.70	9.50	9.30	10.1	9.2	7.6	6.9	6.3	6.0
Thermal Resistance With Heat Sink	K / W	3.35	2.9	1.64	1.66	1.45	1.29	1.00	0.68	0.61	0.77	0.53	0.49
Thermal Resistance Without Heat Sink	K / W	6.79	5.24	4.26	4.35	3.38	2.76	2.99	2.29	1.81	1.87	1.43	1.16
Magnetic Attraction ²	N	0	0	0	0	0	0	0	0	0	0	0	0
Applicable SERVOPACK	SGDV-	R70A	R70A	R90A	1R6A	1R6A	2R8A	1R6A	2R8A	5R5A	2R8A	5R5A	5R5A

*1: These items and "Force and Speed Characteristics" are the values at a motor winding temperature of 100°C during operation in combination with a SERVOPACK. The others are at 20°C.

*2: Logical magnetic attraction acting between the moving coil and the magnetic way. Because of the gap imbalance created after installing the moving coil and the magnetic way, a magnetic attraction is generated.

*3: The rated speed during operation by speed control with an analog voltage reference must be set to 1.5 m/s.

Note: These specifications show the values under the cooling conditions when a heat sink (aluminum board) listed in the following table is mounted on the moving coil.

Heat Sink Size	Applicable Models
100 mm × 200 mm × 12 mm	SGLC-D16A085A, -D16A115A
200 mm × 300 mm × 12 mm	SGLC-D16A145A, -D20A100A, -D20A135A, -D20A170A
300 mm × 400 mm × 12 mm	SGLC-D25A125A, -D32A165A
400 mm × 500 mm × 12 mm	SGLC-D25A170A, -D25A215A, -D32A225A, -D32A285A

Ratings and Specifications

● **Force and Speed Characteristics** [A]: Continuous Duty Zone [B]: Intermittent Duty Zone (Note)

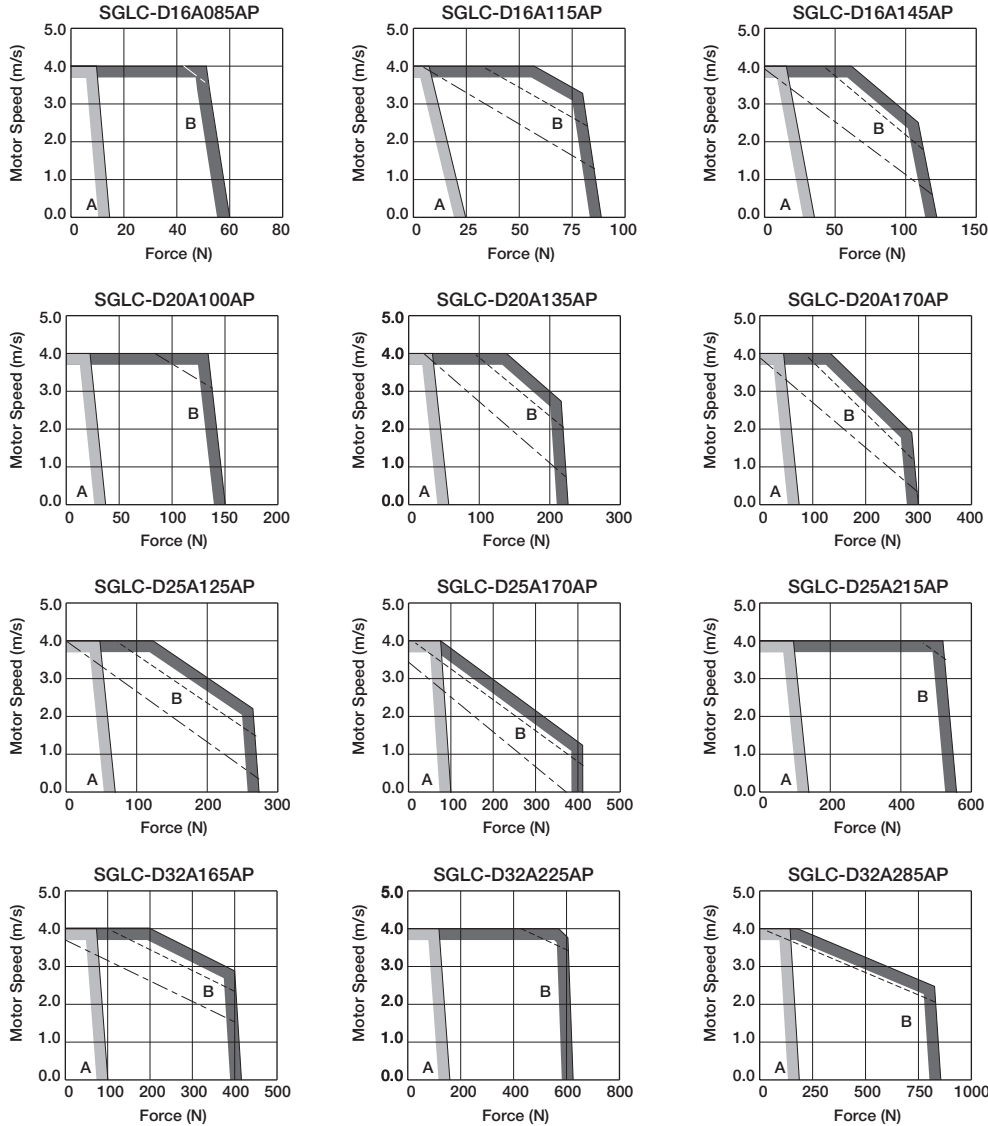

Notes: 1 The characteristics of the intermittent duty zone differ depending on the supply voltages. The solid, dotted, and dashed-dotted lines of the intermittent duty zone indicate the characteristics when a servomotor runs with the following combinations:

- The solid line: With a three-phase 200 V SERVOPACK
- The dotted line: With a single-phase 200 V SERVOPACK
- The dashed-dotted line: With a single-phase 100 V SERVOPACK

SGLC-D16A085AP and SGLC-20A100AP servomotors combined with single-phase 200 V SERVOPACKs have the same characteristics as those combined with three-phase ones.

2 When the effective force is within the rated force, the servomotor can be used within the intermittent duty zone.

● **Mechanical Specifications of Linear Servomotors**

(1) Impact Resistance

- Impact acceleration: 98 m/s²
- Impact occurrences: twice

(2) Vibration Resistance

The linear servomotors will withstand the following vibration acceleration in three directions: Vertical, side to side, and front to back.

- Vibration acceleration: Moving Coil: 24.5 m/s²
Magnetic Way: 24.5 m/s² in axis direction
4.9 m/s² in vertically and horizontally

External Dimensions Units: mm

(1) SGLC-D16

- Moving Coil: SGLCW-D16A□□□AP (With a connector by Tyco Electronics AMP K.K.)

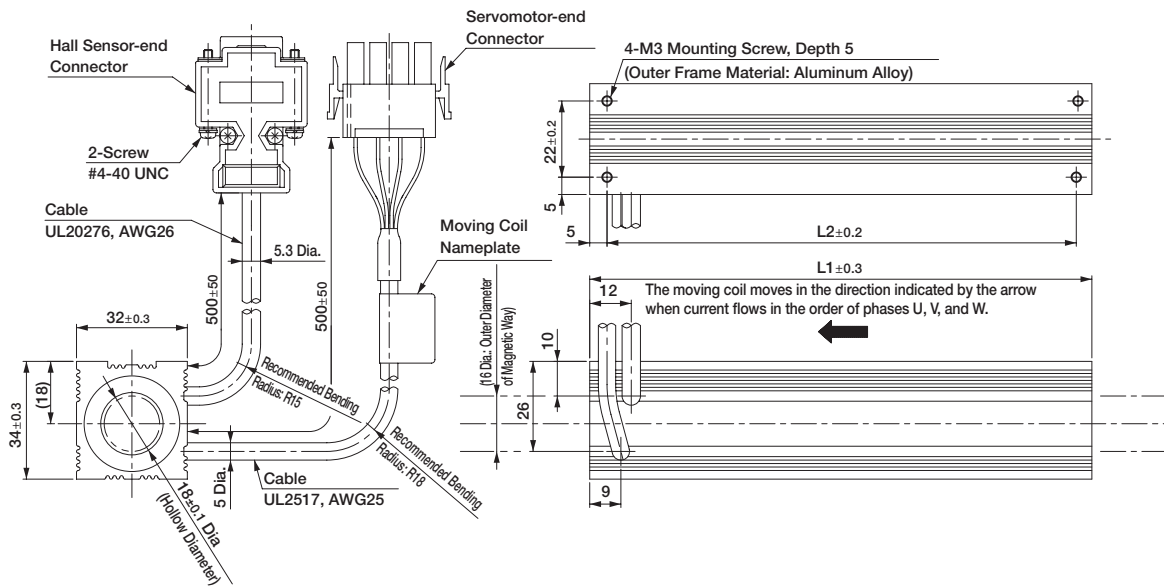

Moving Coil Model SGLCW-	L1	L2	Approx. Mass* kg
D16A085AP	85	75	0.3
D16A115AP	115	105	0.4
D16A145AP	145	135	0.5

*: The values indicate the mass of moving coil with a hall sensor unit.

Hall Sensor Connector Specifications

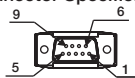

Pin Connector:
17JE-23090-02 (D8C)
by DDK Ltd.

The Mating Connector

Socket Connector:
17JE-13090-02 (D8C)
Stud: 17L-002C or
17L-002C1

Pin No.	Name
1	+5V (Power supply)
2	Phase U
3	Phase V
4	Phase W
5	0V (Power supply)
6	Not used
7	Not used
8	Not used
9	Not used

Linear Servomotor Connector Specifications

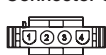

Plug: 350779-1
Pin : 350690-3 or
350561-3 (No.1 to 3)
770210-1 (No.4)

by Tyco
Electronics AMP K.K.
The Mating Connector

Cap: 350780-1
Socket: 350925-1 or
770673-1

Pin No.	Name	Wire Color
1	Phase U	Red
2	Phase V	White
3	Phase W	Blue
4	FG	Green

Hall Sensor Output Signals

When the moving coil moves in the direction indicated by the arrow in the figure, the relationship between the hall sensor output signals Su, Sv, Sw and the inverse power of each motor phase Vu, Vv, Vw becomes as shown in the figure below.

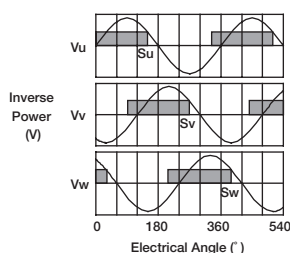

External Dimensions Units: mm

• Magnetic Way: SGLCM-D16□□□A

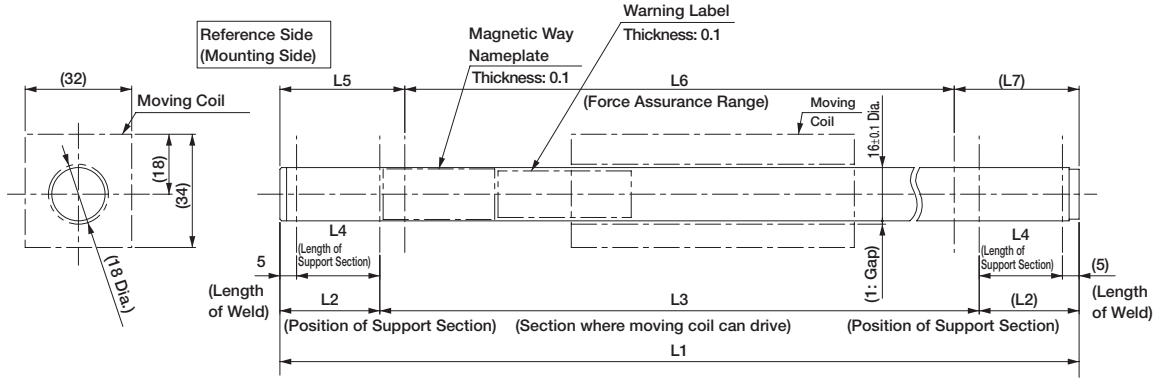

- Notes:1 The magnetic way will become deformed if a magnetic attraction with the moving coil is generated.
 Take measures over the entire driving range to prevent any interference between the magnetic way and the moving coil after installation.
 2 If you have a pacemaker or any other electronic medical device, do not go near the magnetic way of the linear servomotor.

Magnetic Way Model SGLCM-	L1	L2	L3	L4	L5	L6	L7	Approx. Mass kg	Remarks
D16240A	240±1.6	30	180	25	37.5±0.3	165±1.2	37.5	0.38	-
D16270A	270±1.6	30	210	25	37.5±0.3	195±1.2	37.5	0.43	-
D16300A	300±1.6	30	240	25	37.5±0.3	225±1.2	37.5	0.48	Standard
D16330A	330±1.6	30	270	25	37.5±0.3	255±1.2	37.5	0.53	-
D16360A	360±1.6	30	300	25	37.5±0.3	285±1.2	37.5	0.58	-
D16390A	390±1.6	30	330	25	37.5±0.3	315±1.2	37.5	0.63	-
D16420A	420±1.6	30	360	25	37.5±0.3	345±1.2	37.5	0.68	-
D16480A	480±2.5	45	390	40	52.5±0.3	375±2.1	52.5	0.75	-
D16510A	510±2.5	45	420	40	52.5±0.3	405±2.1	52.5	0.80	Standard
D16540A	540±2.5	45	450	40	52.5±0.3	435±2.1	52.5	0.85	-
D16570A	570±2.5	45	480	40	52.5±0.3	465±2.1	52.5	0.90	-
D16600A	600±2.5	45	510	40	52.5±0.3	495±2.1	52.5	0.95	-
D16630A	630±2.5	45	540	40	52.5±0.3	525±2.1	52.5	1.0	-
D16660A	660±2.5	45	570	40	52.5±0.3	555±2.1	52.5	1.05	-
D16690A	690±2.5	45	600	40	52.5±0.3	585±2.1	52.5	1.1	-
D16720A	720±2.5	45	630	40	52.5±0.3	615±2.1	52.5	1.15	-
D16750A	750±3	45	660	40	52.5±0.3	645±2.5	52.5	1.2	Standard

External Dimensions Units: mm

(2) SGLC-D20

• Moving Coil: SGLCW-D20A□□□AP (With a connector by Tyco Electronics AMP K.K.)

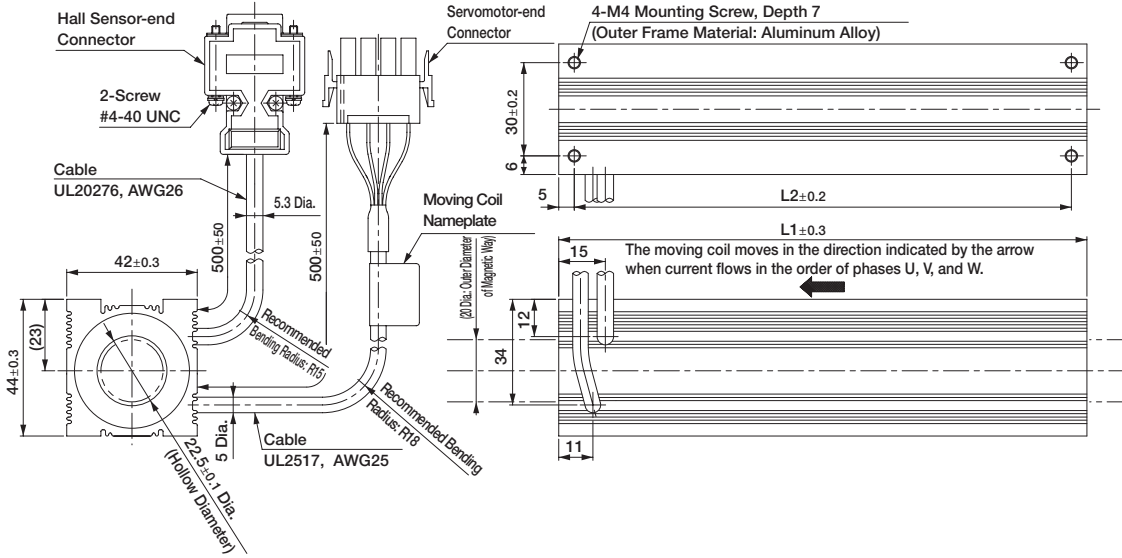

Moving Coil Model SGLCW-	L1	L2	Approx. Mass* kg
D20A100AP	100	90	0.6
D20A135AP	135	125	0.8
D20A170AP	170	160	1.0

*: The values indicate the mass of moving coil with a hall sensor unit.

Hall Sensor Connector Specifications

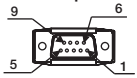

Pin Connector:
17JE-23090-02 (D8C)
by DDK Ltd.

The Mating Connector

Socket Connector:
17JE-13090-02 (D8C)
Stud: 17L-002C or
17L-002C1

Pin No.	Name
1	+5V (Power supply)
2	Phase U
3	Phase V
4	Phase W
5	0V (Power supply)
6	Not used
7	Not used
8	Not used
9	Not used

Linear Servomotor Connector Specifications



Plug: 350779-1
Pin : 350690-3 or
350561-3 (No.1 to 3)
770210-1 (No.4)

by Tyco
Electronics AMP K.K.
The Mating Connector

Cap: 350780-1
Socket: 350925-1 or
770673-1

Pin No.	Name	Wire Color
1	Phase U	Red
2	Phase V	White
3	Phase W	Blue
4	FG	Green

Hall Sensor Output Signals

When the moving coil moves in the direction indicated by the arrow in the figure, the relationship between the hall sensor output signals Su, Sv, Sw and the inverse power of each motor phase Vu, Vv, Vw becomes as shown in the figure below.

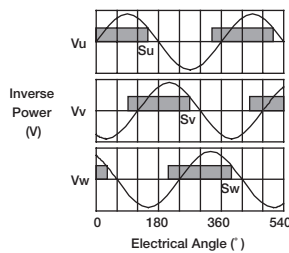

External Dimensions Units: mm

• Magnetic Way: SGLCM-D20□□□A

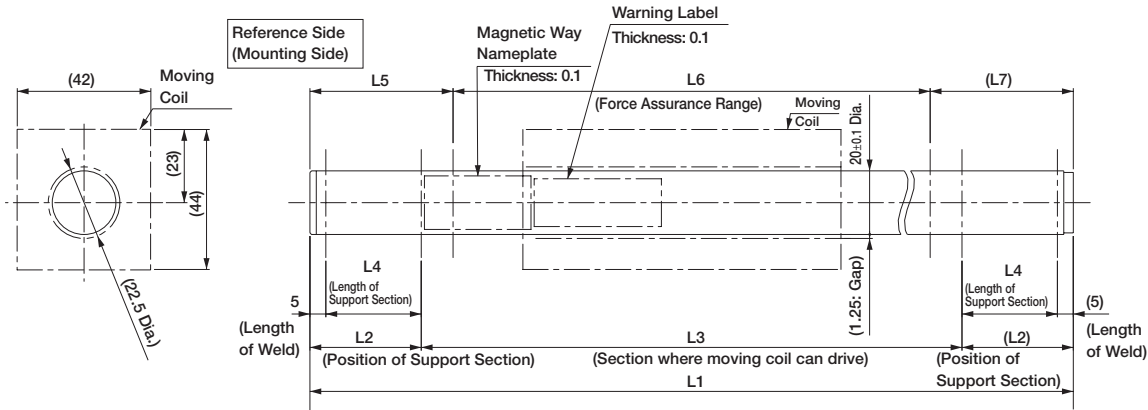

- Notes: 1 The magnetic way will become deformed if a magnetic attraction with the moving coil is generated.
 Take measures over the entire driving range to prevent any interference between the magnetic way and the moving coil after installation.
 2 If you have a pacemaker or any other electronic medical device, do not go near the magnetic way of the linear servomotor.

Magnetic Way Model SGLCM-	L1	L2	L3	L4	L5	L6	L7	Approx. Mass kg	Remarks
D20280A	280±1.6	35	210	30	45±0.3	190±1.2	45	0.68	-
D20315A	315±1.6	35	245	30	45±0.3	225±1.2	45	0.77	-
D20350A	350±1.6	35	280	30	45±0.3	260±1.2	45	0.86	Standard
D20385A	385±1.6	35	315	30	45±0.3	295±1.2	45	0.95	-
D20420A	420±1.6	35	350	30	45±0.3	330±1.2	45	1.0	-
D20455A	455±1.6	35	385	30	45±0.3	365±1.2	45	1.1	-
D20490A	490±1.6	35	420	30	45±0.3	400±1.2	45	1.2	-
D20555A	555±2.5	50	455	45	60±0.3	435±2.1	60	1.35	-
D20590A	590±2.5	50	490	45	60±0.3	470±2.1	60	1.45	Standard
D20625A	625±2.5	50	525	45	60±0.3	505±2.1	60	1.55	-
D20660A	660±2.5	50	560	45	60±0.3	540±2.1	60	1.6	-
D20695A	695±2.5	50	595	45	60±0.3	575±2.1	60	1.7	-
D20730A	730±2.5	50	630	45	60±0.3	610±2.1	60	1.8	-
D20765A	765±2.5	50	665	45	60±0.3	645±2.1	60	1.9	-
D20800A	800±2.5	50	700	45	60±0.3	680±2.1	60	2.0	-
D20835A	835±2.5	50	735	45	60±0.3	715±2.1	60	2.1	-
D20870A	870±3	50	770	45	60±0.3	750±2.5	60	2.2	Standard

External Dimensions Units: mm

(3) SGLC-D25

- Moving Coil: SGLCW-D25A□□□AP (With a connector by Tyco Electronics AMP K.K.)

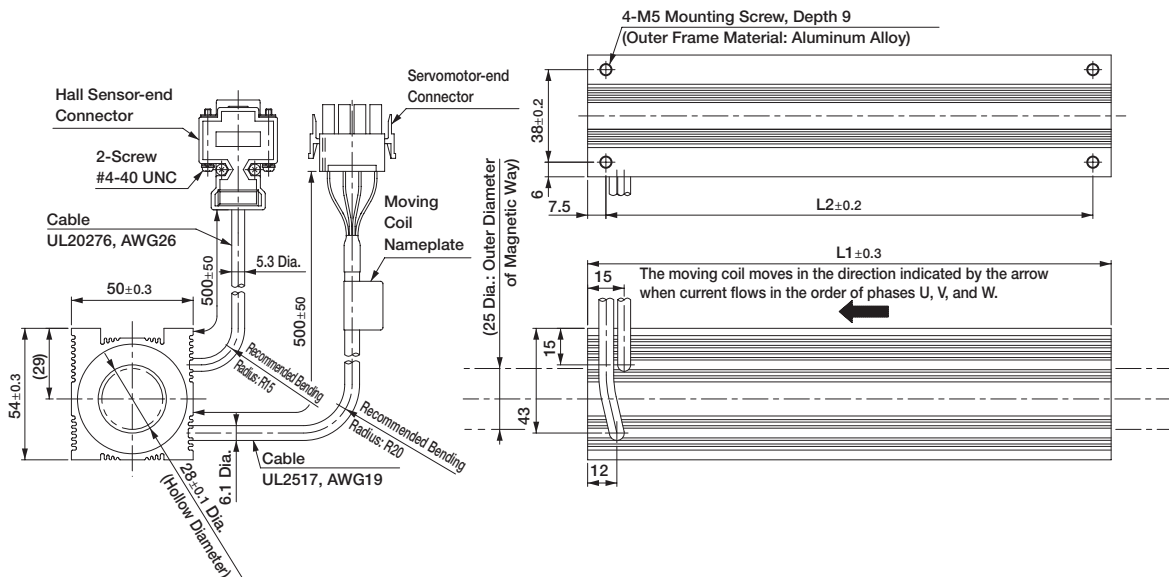

Moving Coil Model SGLCW-	L1	L2	Approx. Mass* kg
D25A125AP	125	110	1.0
D25A170AP	170	153	1.4
D25A215AP	215	200	1.8

*: The values indicate the mass of moving coil with a hall sensor unit.

Hall Sensor Connector Specifications



Pin Connector:
17JE-23090-02 (D8C)
by DDK Ltd.

The Mating Connector

Socket connector:
17JE-13090-02 (D8C)
Stud: 17L-002C or
17L-002C1

Pin No.	Name
1	+5V (Power supply)
2	Phase U
3	Phase V
4	Phase W
5	0V (Power supply)
6	Not used
7	Not used
8	Not used
9	Not used

Linear Servomotor Connector Specifications



Plug: 350779-1
Pin: (No. 1 to 3)
350561-3 or 350690-3
(No. 4)
350654-1 or 350669-1

by Tyco Electronics AMP K.K.

The Mating Connector

Cap : 350780-1
Socket: 350925-1 or
770673-1

Pin No.	Name	Wire Color
1	Phase U	Red
2	Phase V	White
3	Phase W	Blue
4	FG	Green

Hall Sensor Output Signals

When the moving coil moves in the direction indicated by the arrow in the figure, the relationship between the hall sensor output signals S_u , S_v , S_w and the inverse power of each motor phase V_u , V_v , V_w becomes as shown in the figure below.

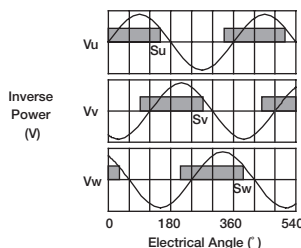

External Dimensions Units: mm

• Magnetic Way: SGLCM-D25□□□A

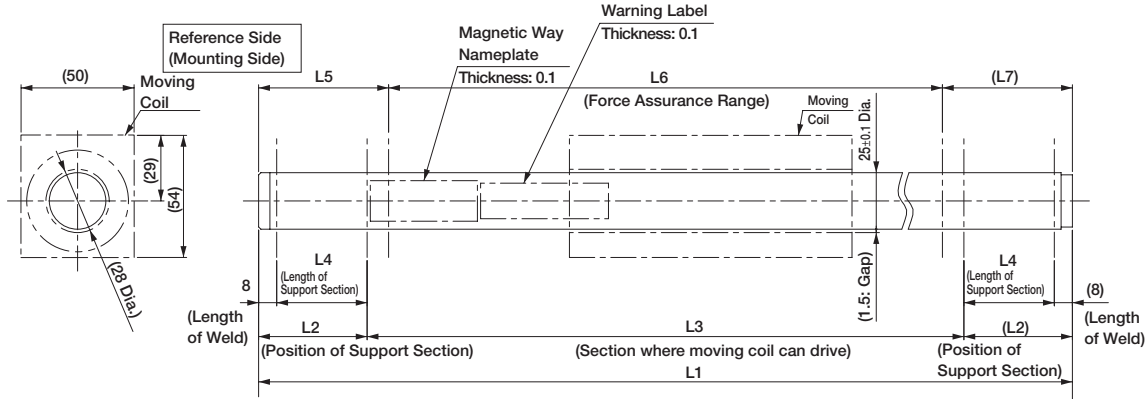

- Notes: 1 The magnetic way will become deformed if a magnetic attraction with the moving coil is generated. Take measures over the entire driving range to prevent any interference between the magnetic way and the moving coil after installation.
2 If you have a pacemaker or any other electronic medical device, do not go near the magnetic way of the linear servomotor.

Magnetic Way Model SGLCM-	L1	L2	L3	L4	L5	L6	L7	Approx. Mass kg	Remarks
D25360A	360±1.6	45	270	37	57.5±0.3	245±1.2	57.5	1.5	-
D25405A	405±1.6	45	315	37	57.5±0.3	290±1.2	57.5	1.65	-
D25450A	450±1.6	45	360	37	57.5±0.3	335±1.2	57.5	1.8	Standard
D25495A	495±1.6	45	405	37	57.5±0.3	380±1.2	57.5	1.95	-
D25540A	540±1.6	45	450	37	57.5±0.3	425±1.2	57.5	2.1	-
D25585A	585±1.6	45	495	37	57.5±0.3	470±1.2	57.5	2.25	-
D25630A	630±1.6	45	540	37	57.5±0.3	515±1.2	57.5	2.4	-
D25705A	705±2.5	60	585	52	72.5±0.3	560±2.1	72.5	2.85	-
D25750A	750±2.5	60	630	52	72.5±0.3	605±2.1	72.5	3.0	Standard
D25795A	795±2.5	60	675	52	72.5±0.3	650±2.1	72.5	3.15	-
D25840A	840±2.5	60	720	52	72.5±0.3	695±2.1	72.5	3.3	-
D25885A	885±2.5	60	765	52	72.5±0.3	740±2.1	72.5	3.45	-
D25930A	930±2.5	60	810	52	72.5±0.3	785±2.1	72.5	3.6	-
D25975A	975±2.5	60	855	52	72.5±0.3	830±2.1	72.5	3.75	-
D251020A	1020±2.5	60	900	52	72.5±0.3	875±2.1	72.5	3.9	-
D251065A	1065±2.5	60	945	52	72.5±0.3	920±2.1	72.5	4.05	-
D251110A	1110±3	60	990	52	72.5±0.3	965±2.5	72.5	4.2	Standard

External Dimensions Units: mm

(4) SGLC-D32

- Moving Coil: SGLCW-D32A□□□AP (With a connector by Tyco Electronics AMP K.K.)

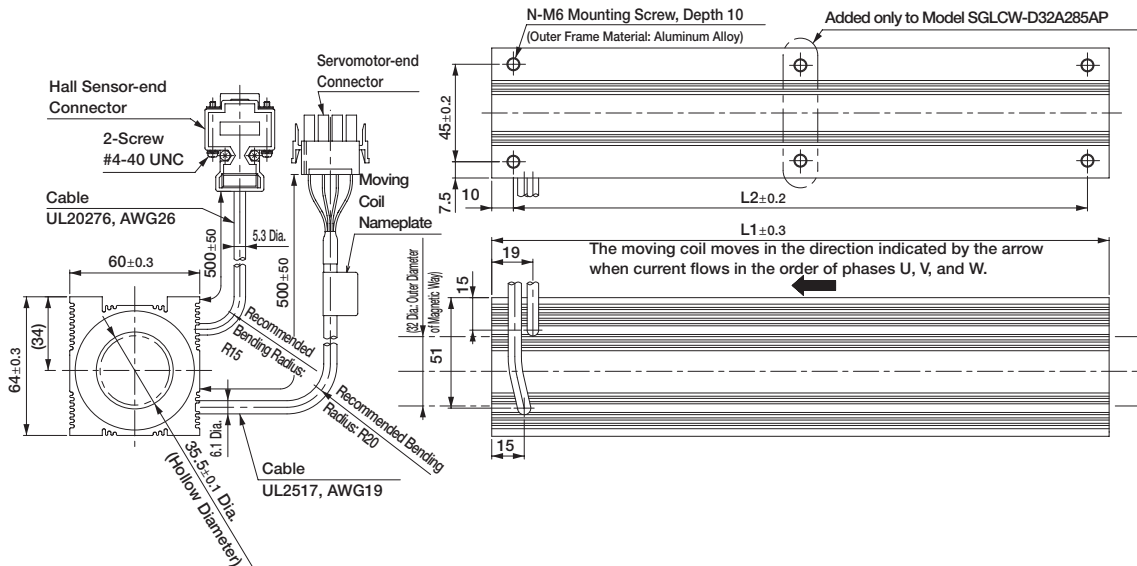

Moving Coil Model SGLCW-	L1	L2	N	Approx. Mass* kg
D32A165AP	165	145	4	1.8
D32A225AP	225	205	4	2.5
D32A285AP	285	265	6	3.2

*: The values indicate the mass of moving coil with a hall sensor unit.

Hall Sensor Connector Specifications



Pin Connector:
17JE-23090-02 (D8C)
by DDK Ltd.

The Mating Connector

Socket connector:
17JE-13090-02 (D8C)
Stud: 17L-002C or
17L-002C1

Pin No.	Name
1	+5V (Power supply)
2	Phase U
3	Phase V
4	Phase W
5	0V (Power supply)
6	Not used
7	Not used
8	Not used
9	Not used

Linear Servomotor Connector Specifications

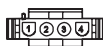

Plug: 350779-1
Pin: (No. 1 to 3)
350561-3 or 350690-3
(No. 4)
350654-1 or 350669-1
by Tyco Electronics AMP K.K.

The Mating Connector

Cap: 350780-1
Socket: 350925-1 or
770673-1

Pin No.	Name	Wire Color
1	Phase U	Red
2	Phase V	White
3	Phase W	Blue
4	FG	Green

Hall Sensor Output Signals

When the moving coil moves in the direction indicated by the arrow in the figure, the relationship between the hall sensor output signals S_u , S_v , S_w and the inverse power of each motor phase V_u , V_v , V_w becomes as shown in the figure below.

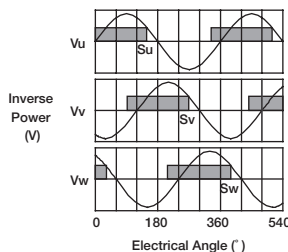

External Dimensions Units: mm

• Magnetic Way: SGLCM-D32□□□A

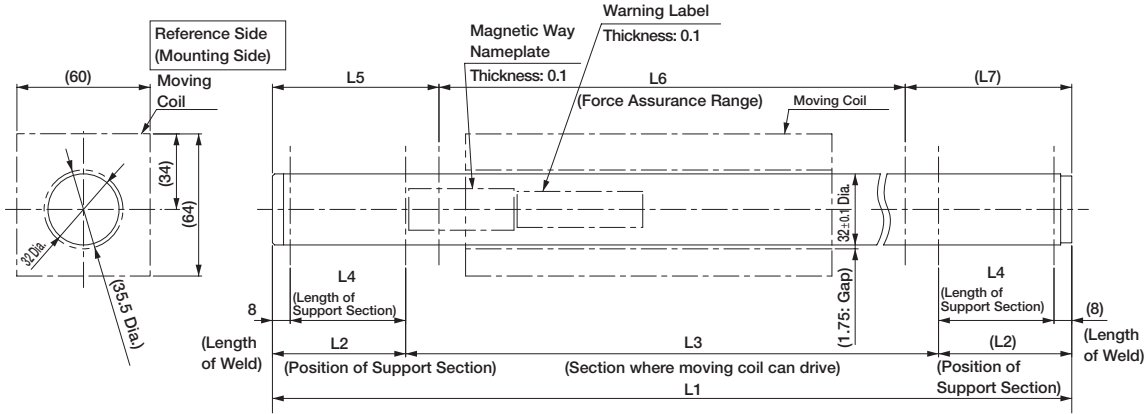

- Notes: 1 The magnetic way will become deformed if a magnetic attraction with the moving coil is generated.
 Take measures over the entire driving range to prevent any interference between the magnetic way and the moving coil after installation.
 2 If you have a pacemaker or any other electronic medical device, do not go near the magnetic way of the linear servomotor.

Magnetic Way Model SGLCM-	L1	L2	L3	L4	L5	L6	L7	Approx. Mass kg	Remarks
D32480A	480±1.6	60	360	52	75±0.3	330±1.2	75	3.0	-
D32540A	540±1.6	60	420	52	75±0.3	390±1.2	75	3.4	-
D32600A	600±1.6	60	480	52	75±0.3	450±1.2	75	3.8	Standard
D32660A	660±1.6	60	540	52	75±0.3	510±1.2	75	4.2	-
D32720A	720±1.6	60	600	52	75±0.3	570±1.2	75	4.6	-
D32780A	780±1.6	60	660	52	75±0.3	630±1.2	75	5.0	-
D32840A	840±1.6	60	720	52	75±0.3	690±1.2	75	5.4	-
D32960A	960±2.5	90	780	82	105±0.3	750±2.1	105	5.9	-
D321020A	1020±2.5	90	840	82	105±0.3	810±2.1	105	6.3	Standard
D321080A	1080±2.5	90	900	82	105±0.3	870±2.1	105	6.7	-
D321140A	1140±2.5	90	960	82	105±0.3	930±2.1	105	7.1	-
D321200A	1200±2.5	90	1020	82	105±0.3	990±2.1	105	7.5	-
D321260A	1260±2.5	90	1080	82	105±0.3	1050±2.1	105	7.9	-
D321320A	1320±2.5	90	1140	82	105±0.3	1110±2.1	105	8.3	-
D321380A	1380±2.5	90	1200	82	105±0.3	1170±2.1	105	8.7	-
D321440A	1440±2.5	90	1260	82	105±0.3	1230±2.1	105	9.1	-
D321500A	1500±3	90	1320	82	105±0.3	1290±2.5	105	9.5	Standard

Selecting Cables

● Cables Connections

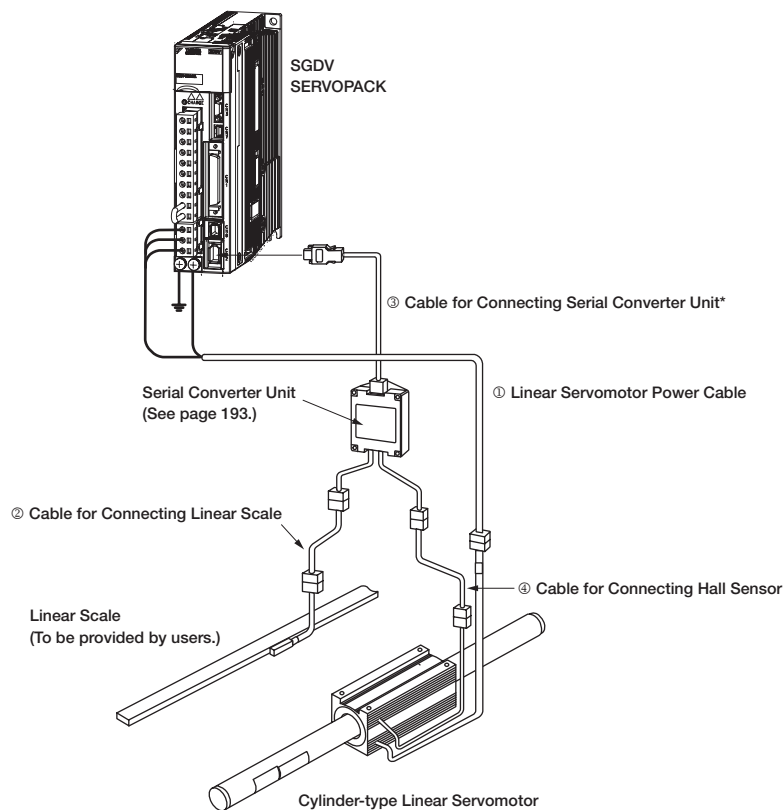

*: A serial converter unit can be connected directly to an absolute linear scale.

● Cables

Name	Applicable Linear Servomotor Model	Length	Order No.	Specifications	Details
① Linear Servomotor Power Cables	All models	1 m	JZSP-CLN11-01-E	SERVOPACK End Linear Servomotor End 	(1)
		3 m	JZSP-CLN11-03-E		
		5 m	JZSP-CLN11-05-E		
		10 m	JZSP-CLN11-10-E		
		15 m	JZSP-CLN11-15-E		
② Cables for Connecting Linear Scales*	All models	1 m	JZSP-CLL00-01-E-G#	Serial Converter Unit End Linear Scale End 	(2)
		3 m	JZSP-CLL00-03-E-G#		
		5 m	JZSP-CLL00-05-E-G#		
		10 m	JZSP-CLL00-10-E-G#		
		15 m	JZSP-CLL00-15-E-G#		
③ Cables for Connecting Serial Converter Units	All models	1 m	JZSP-CLP70-01-E-G#	SERVOPACK End Serial Converter Unit End 	(3)
		3 m	JZSP-CLP70-03-E-G#		
		5 m	JZSP-CLP70-05-E-G#		
		10 m	JZSP-CLP70-10-E-G#		
		15 m	JZSP-CLP70-15-E-G#		
		20 m	JZSP-CLP70-20-E-G#		
④ Cables for Connecting Hall Sensors	All models	1 m	JZSP-CLL10-01-E-G#	Serial Converter Unit End Hall Sensor Unit End 	(4)
		3 m	JZSP-CLL10-03-E-G#		
		5 m	JZSP-CLL10-05-E-G#		
		10 m	JZSP-CLL10-10-E-G#		
		15 m	JZSP-CLL10-15-E-G#		

*: When using serial converter unit JZDP-G00□-□□□-E, the maximum cable length is 3 m.

Note: The digit "#" of the order number represents the design revision.

Selecting Cables

(1) Linear Servomotor Power Cables:
JZSP-CLN11-□□-E

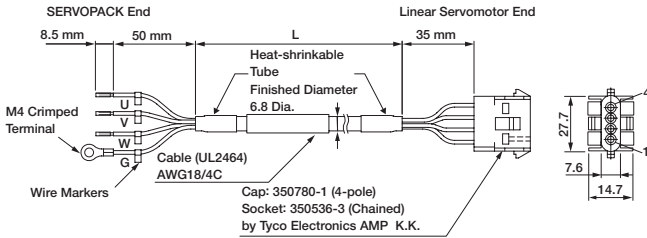

• Wiring Specifications

SERVOPACK-end Leads		Linear Servomotor-end Connector	
Wire Color	Signal	Signal	Pin. No.
Black 1	Phase U	Phase U	1
Black 2	Phase V	Phase V	2
Black 3	Phase W	Phase W	3
Green/yellow	FG	FG	4

(2) Cables for Connecting Linear Scales:
JZSP-CLL00-□□-E-G#

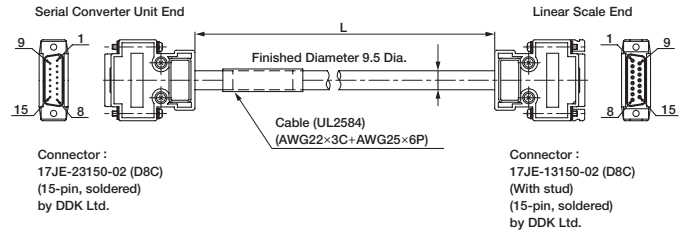

• Wiring Specifications

Serial Converter Unit End		Linear Scale End	
Pin No.	Signal	Pin No.	Signal
1	/Cos(V1-)	1	/Cos(V1-)
2	/Sin(V2-)	2	/Sin(V2-)
3	Ref(V0+)	3	Ref(V0+)
4	+5V	4	+5V
5	5Vs	5	5Vs
6	BID	6	BID
7	Vx	7	Vx
8	Vq	8	Vq
9	Cos(V1+)	9	Cos(V1+)
10	Sin(V2+)	10	Sin(V2+)
11	/Ref(V0+)	11	/Ref(V0-)
12	0V	12	0V
13	0Vs	13	0Vs
14	DIR	14	DIR
15	Inner	15	Inner
Case	Shield	Case	Shield

(3) Cables for Connecting Serial Converter Units:
JZSP-CLP70-□□-E-G#

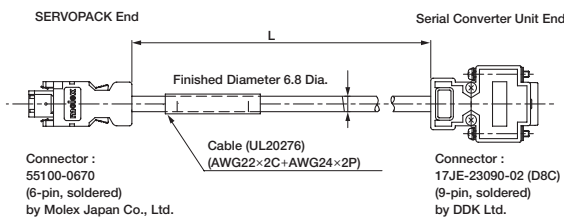

• Wiring Specifications

SERVOPACK End			Serial Converter Unit End		
Pin No.	Signal	Wire Color	Pin No.	Signal	Wire Color
1	PG5V	Red	1	+5V	Red
2	PG0V	Black	5	0V	Black
3	-	-	3	-	-
4	-	-	4	-	-
5	PS	Light blue	2	Phase S output	Light blue
6	/PS	Light blue/white	6	Phase /S output	Light blue/white
Shell	Shield	-	Case	Shield	-
			7	-	-
			8	-	-
			9	-	-

(4) Cables for Connecting Hall Sensors:
JZSP-CLL10-□□-E-G#

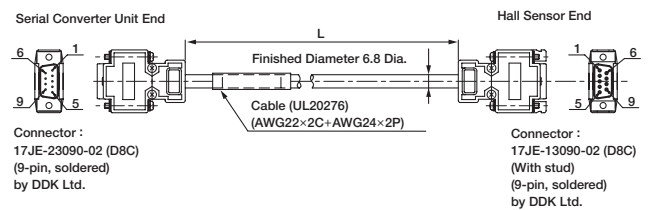

• Wiring Specifications

Serial Converter Unit End		Hall Sensor End	
Pin No.	Signal	Pin No.	Signal
1	+5V	1	+5V
2	Phase U input	2	Phase U input
3	Phase V input	3	Phase V input
4	Phase W input	4	Phase W input
5	0V	5	0V
6	-	6	-
7	-	7	-
8	-	8	-
9	-	9	-
Case	Shield	Case	Shield